

Synergy LED Square Low Profile Deep Recessed

Code: 802193104 (ERLP164SDR.93)

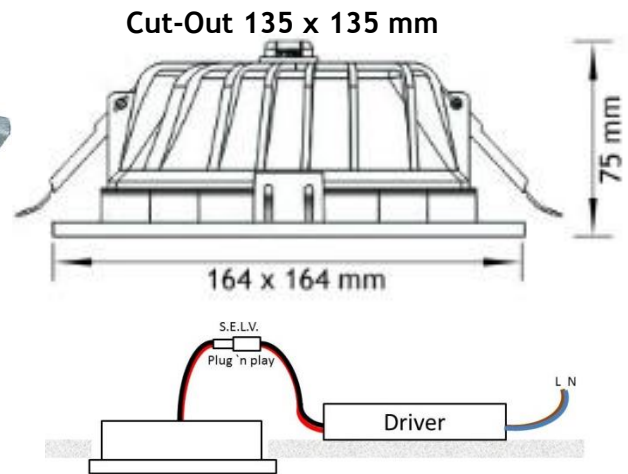

Features

Downlight with LED lamp, complete with SELV driver to suit, pre wired and ready to install:

- Simple fixing
- Energy saving
- Low operating temperature
- Long lifetime LED
- Full intensity from switch on
- Driver with S.E.L.V. output
- Safety Class III luminaire
- Protection Class IP20
- IBL 3 Year warranty on fittings and drivers

Technical data

Dimensions:	Height: 75 mm Length: 164 mm Width: 164 mm
Weight:	0,5 kg net.
Installation Depth:	85 mm
cut-out:	135 x 135 mm
max ceiling thickness	30 mm
Weight:	ca. 0,7 kg incl. driver
Material:	die-cast aluminium
Max. surface Temperature.:	65 °C
Colour:	Silver-grey
Anticipated install time:	10 min

Certification



Electrical Data

LED DRIVER:	
Output type	constant current
Input voltage	220-240 Vac, 50-60 Hz 110-127 Vac, 50-60 Hz* 90-305 Vac, 50-60 Hz**
Input current	max. 0,07 A max. 0,14 A/**
cos phi	>0,95 0,93* >0,9**
Output current	700 mA constant
Output voltage	max. 29 Vdc
Electrical safety Class	II
Output isolation	S.E.L.V.
Protection Class	IP20

LUMINAIRE

Electrical safety Class	III
Protection Class	IP20
Power	15W @ 700 mA
Warm White	2875-3200K
Beam	105 °

WARNING Do NOT switch using TRIAC-based (transistor, thyristor) circuits. Damage to driver inevitable

ECO-Dashboard



LED specification

LED lighting unit with Epistar 5630 Chip	
Color Temperature CCT	3000 K
Light Output	approx. 800 lm
CRI	≥ 80
Average Lifetime (L70)	45 000 h

Contact

IBL Lighting GmbH
Christinenstr. 11
D-40880 Ratingen
Tel: 02102- 94 20 66 0
Fax: 02102- 94 20 66 6
web: www.ibl.eu
email: info@ibl.eu